

Modular contactors 25 A



Internal light management



Ancillary equipment



Mobile device charging

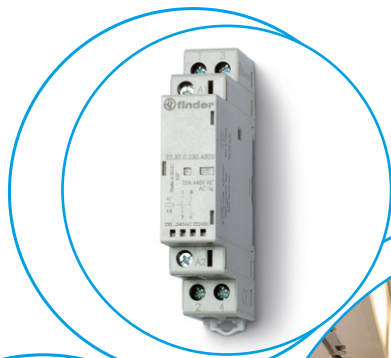

22
SERIES

25 A modular contactor - 2 pole or 4 pole

- Complies with EN 45545-2:2020 (protection against fire of materials), EN 61373 (resistance against random vibrations and shock, Category 1, Class B), EN 50155 (resistance to temperature and humidity, OT4/ST1 class)
- 17.5 or 35 mm wide
- NO contact gap ≥ 3 mm, double break
- Continuous duty for the coil and contacts
- AC/DC silent coil (with varistor protection)
- Protective separation (reinforced insulation) between coil and contacts
- Mechanical and LED indicators
- Compliant with EN 61095: 2009
- Auxiliary contact module available, quick-assembly with the main contactor (1 NO + 1 NC and 2 NO versions)
- 35 mm rail (EN 60715) mount

22.32...4x20/22.34...4x20

Screw terminal



* Contact gap ≥ 3 mm for NO contacts only; NC contacts ≥ 1.5 mm

For outline drawings see page 7

Contact specification

Contact configuration	2 NO, 3 mm* (or 1 NO + 1 NC or 2 NC)	4 NO, 3 mm* (or 3 NO + 1 NC or 2 NO + 2 NC)
Rated current/Maximum peak current	A 25/120	25/120
Rated voltage	V AC 250/440	250/440
Rated load AC1 / AC-7a (per pole @ 250 V)	VA 6250	6250
Rated current AC3 / AC-7b	A 10	10
Rated load AC15 (per pole @ 230 V)	VA 1800	1800
Single-phase motor rating (230 V AC)	kW 1	4
Three-phase motor rating (400 - 440 V AC)	A 15	15
Rated current AC-7c	A 10	10
Nominal lamp rating:		
230 V incandescent/halogen W	2000	2000
fluorescent tubes with electronic ballast W	800	800
fluorescent tubes with electromechanical ballast W	500	500
CFL W	200	200
230 V LED W	200	200
LV halogen or LED with electronic ballast W	200	200
LV halogen or LED with electromechanical ballast W	800	800
Breaking capacity DC1: 24/110/220 V	A 25/5/1	25/5/1
Minimum switching load	mW (V/mA) 1000 (10/10)	1000 (10/10)
Contact material	AgSnO ₂	AgSnO ₂
Coil specification		
Nominal voltage (U _N)	V DC/AC (50/60 Hz) 12 - 24 - 48 - 60 - 120 - 230	12 - 24 - 48 - 60 - 120 - 230
Rated power AC/DC	VA (50 Hz)/W 2/2.2	2/2.2
Operating range	DC/AC (50/60 Hz) (0.8...1.1)U _N	(0.8...1.1)U _N
Holding voltage	DC/AC (50/60 Hz) 0.4 U _N	0.4 U _N
Must drop-out voltage	DC/AC (50/60 Hz) 0.1 U _N	0.1 U _N
Technical data		
Mechanical life AC/DC	cycles 2 · 10 ⁶	2 · 10 ⁶
Electrical life at rated load AC-7a	cycles 30 · 10 ³	30 · 10 ³
Operate/release time	ms 30/20	18/40
Insulation between coil and contacts (1.2/50 μs)	kV 6	6
Ambient temperature range	°C -20...+50	-20...+50
Protection category	IP 20	IP 20
Approvals (according to type)	CE UK EAC RINA cULus	

22.32.0.xxx.4x20



- AgSnO₂ contacts, specifically intended for lamp loads and for high inrush current loads

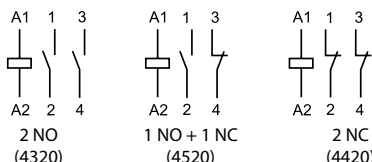

22.34.0.xxx.4x20



- AgSnO₂ contacts, specifically intended for lamp loads and for high inrush current loads

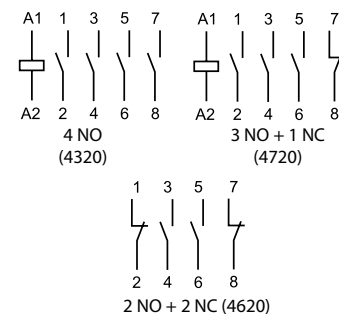

Ordering information

Example: 22 series, modular contactor 25 A, 4 NO contacts, coil 24 V AC/DC, AgSnO₂ contacts, mechanical indicator + LED.

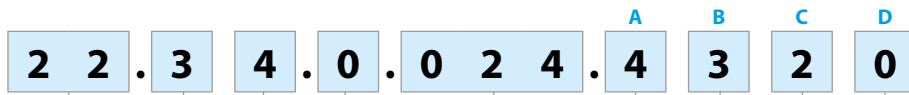

Series ————
Type ————
 3 = 25 A modular contactor range
Number of contacts ————
 2 = 2 pole
 4 = 4 pole
Coil version ————
 0 = AC (50/60 Hz)/DC
Coil rated voltage ————
 See coil specifications

D: Special versions
 0 = Standard
C: Options
 2 = Mechanical indicator + LED
B: Contact circuit
 3 = All NO contacts
 4 = All NC contacts (22.32 only)
 5 = 1 NO + 1 NC
 6 = 2 NO + 2 NC
 7 = 3 NO + 1 NC
A: Contact material
 4 = AgSnO₂

Selecting features and options: only combinations in the same row are possible.
 Preferred selections for best availability are shown in **bold**.

Type	Coil version	A	B	C	D
22.32	AC/DC	4	3 - 4 - 5	2	0
22.34	AC/DC	4	3 - 6 - 7	2	0

Technical data

Insulation		22.32/22.34	
Rated insulation voltage	V AC	250	440
Pollution degree		3	2
Insulation between coil and contact set			
Type of insulation		Reinforced	
Overvoltage category		III	
Rated impulse voltage	kV (1.2/50 μs)	6	
Dielectric strength	V AC	4000	
Insulation between adjacent contacts			
Type of insulation		Basic	
Overvoltage category		III	
Rated impulse voltage	kV (1.2/50 μs)	4	
Dielectric strength	V AC	2500	
Insulation between open contacts			
		NO contact	NC contact
Contact gap	mm	3	1.5
Overvoltage category		III	II
Rated impulse voltage	kV (1.2/50 μs)	4	2.5
Dielectric strength	V AC/kV (1.2/50 μs)	2500/4	2000/3
Insulation between coil terminals			
Rated impulse voltage (surge) differential mode (according to EN 50121)	kV (1.2/50 μs)	4	
Short circuit protection			
Rated conditional short circuit current	kA	3	
Back-up fuse	A	32 (gL/gG type)	
Terminals			
Solid and stranded cable			
Max. wire size – contact terminals	mm ²	1 x 6 / 2 x 4	
	AWG	1 x 10 / 2 x 12	
Max. wire size – coil terminals	mm ²	1 x 4 / 2 x 2.5	
	AWG	1 x 12 / 2 x 14	
Min. wire size – contact and coil terminals	mm ²	1 x 0.2	
	AWG	1 x 24	
Screw torque	Nm	0.8	
Wire strip length	mm	9	
Other data		22.32	22.34
Vibration resistance		According to EN 61373	
Shock resistance		According to EN 61373	
Power lost to the environment	without contact current	W	2
	with rated current	W	4.8
			6.3

NOTE: It is suggested an air gap of 9 mm between adjacent relays for installations and working conditions close to the limit (that is, ambient temperature > 40 °C, coil operated for a prolonged period of time, all contacts loaded with current > 20 A).

Contact specification

Ratings and utilization categories according to EN 61095: 2009

Type	Utilization category					
	AC-7a		AC-7b		AC-7c	
	Rated current (A)	Rated electrical life (Cycles)	Rated current (A)	Rated electrical life (Cycles)	Rated current (A)	Rated electrical life (Cycles)
22.32...4xx0 (AgSnO ₂ contacts)	25	30 · 10 ³	10	30 · 10 ³	10	30 · 10 ³
22.34...4xx0 (AgSnO ₂ contacts)	25	30 · 10 ³	10	30 · 10 ³	10	30 · 10 ³

Utilization category: **AC-7a** = Slightly inductive loads ($\cos\phi = 0.8$)

AC-7b = Motor loads; ($\cos\phi = 0.45$, $I_{\text{making}} = 6 \times I_{\text{breaking}}$)

AC-7c = Compensated electric discharge lamps ($\cos\phi = 0.9$, $C = 10 \text{ mF/A}$)

H 22 - Maximum DC1 breaking capacity - Type 22.32/22.34

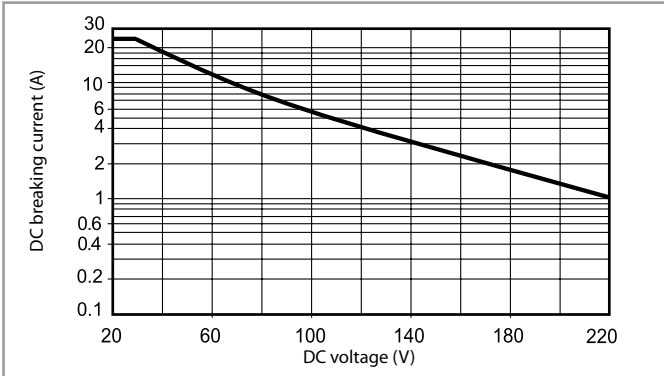

- When switching a resistive load (DC1) having voltage and current values under the curve, an electrical life of $\geq 100 \cdot 10^3$ can be expected.
- In the case of DC13 loads, the connection of a diode in parallel with the load will permit a similar electrical life as for a DC1 load.
Note: the release time for the load will be increased.

Coil specifications

AC/DC version data (type 22.32)

Nominal voltage U_N V	Coil code	Operating range		Rated coil consumption I_N at U_N (AC) mA
		U_{\min} V	U_{\max} V	
12	0.012	9.6	13.2	165
24	0.024	19.2	26.4	83
48	0.048	38.4	52.8	42
60	0.060	48	66	33
120 (110...125)	0.120	88	138	16.5
230 (230...240 AC) (220 DC)	0.230	184 (AC) 176 (DC)	264 (AC) 242 (DC)	8.7

AC/DC version data (type 22.34)

Nominal voltage U_N V	Coil code	Operating range		Rated coil consumption I_N at U_N (AC) mA
		U_{\min} V	U_{\max} V	
12	0.012	9.6	13.2	165
24	0.024	19.2	26.4	83
48	0.048	38.4	52.8	42
60	0.060	48	66	33
120 (110...125)	0.120	88	138	16.5
230 (230...240 AC) (220 DC)	0.230	184 (AC) 176 (DC)	264 (AC) 242 (DC)	8.7

R 22 - Coil operating range v ambient temperature

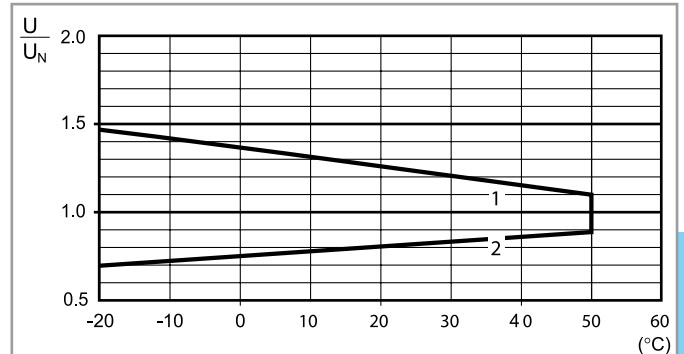

1 - Max. permitted coil voltage.

2 - Min. pick-up voltage with coil at ambient temperature.

Wiring diagrams

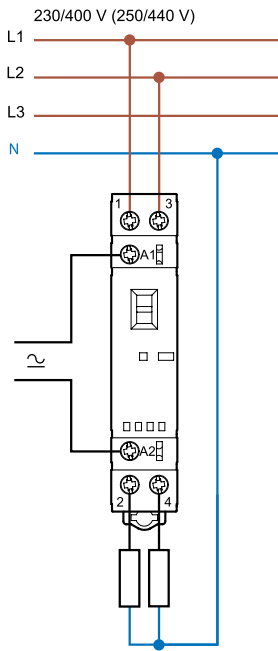

Type 22.32

Line and neutral switched

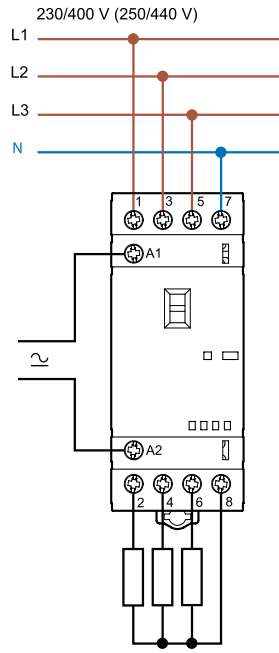

Type 22.34

Line only switched

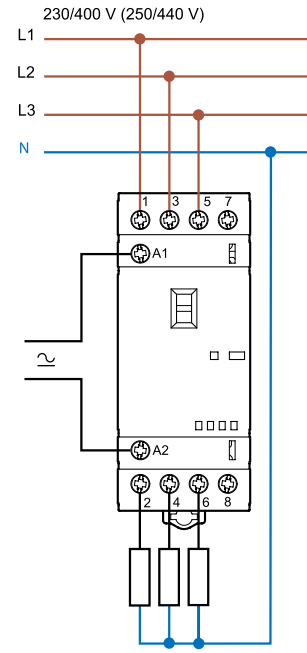

Type 22.34

Outline drawings

Type 22.32
Screw terminal

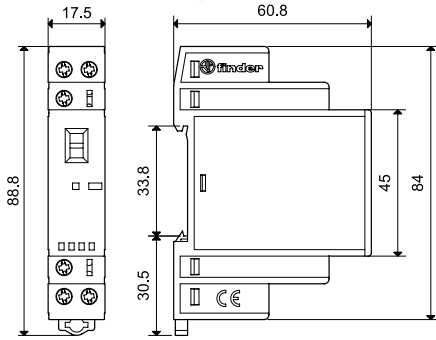

Type 22.32 + 022.33/022.35
Screw terminal

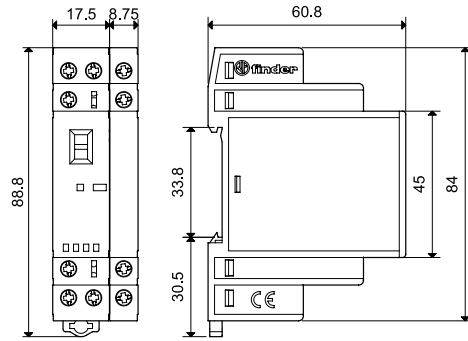

Type 22.34
Screw terminal

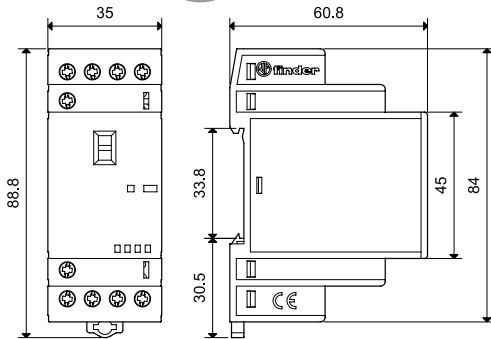

Type 22.34 + 022.33/022.35
Screw terminal

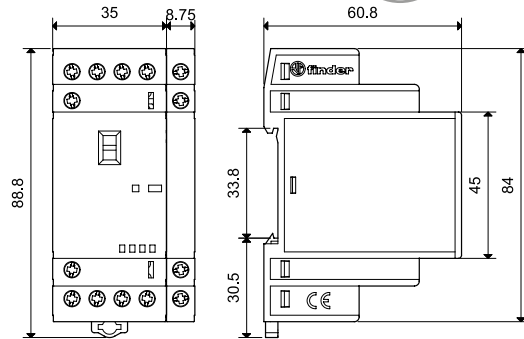

Type 022.33/022.35
Screw terminal

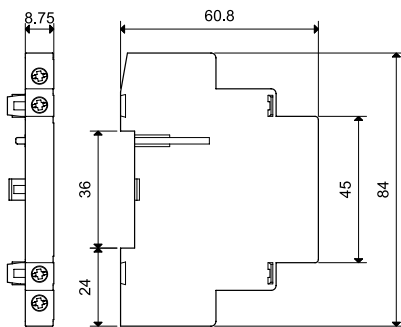

Auxiliary modules

022.33



022.35

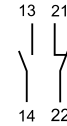

Type of contactor	Type 22.32 Type 22.34	Type 22.32 Type 22.34
Contact specification		
Contact configuration	2 NO	1 NO + 1 NC
Conventional free air thermal current I_{th}	A	6
Rated power AC15 (230 V)	VA	700
Electrical life at rated load	cycles	$30 \cdot 10^3$
Contact material	AgNi	AgNi
Short circuit protection		
Rated conditional short circuit current	kA	1
Back-up fuse	A	6 (gL/gG type)
Terminals		
Solid and stranded cable		
Max. wire size	mm ²	1 x 4 / 2 x 2.5
	AWG	1 x 12 / 2 x 14
Min. wire size	mm ²	1 x 0.2
	AWG	1 x 24
Screw torque	Nm	0.8
Wire strip length	mm	9
Power lost to the environment		
without contact current	W	—
with rated current	W	0.5
Approvals (according to type)		

NOTE: It is not possible to assembly the auxiliary module on 22.32.0.xxx.x4x0 (2 NC versions).



22.32 + 022.33/022.35



22.34 + 022.33/022.35

Accessories



020.01

Adaptor for panel mounting (for 22.32 type), plastic, 17.5 mm wide

020.01

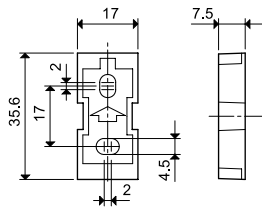

011.01

Adaptor for panel mounting (for 22.34 type), plastic, 35 mm wide

011.01

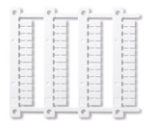
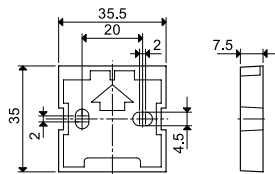

060.48

Sheet of marker tags, plastic, 48 tags, 6 x 12 mm, for CEMBRE's thermal transfer printers

060.48

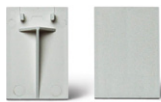

019.01

Identification tag, plastic, 1 tag, 17 x 25.5 mm

019.01



022.09

Separator for rail mounting, plastic, 9 mm wide

022.09

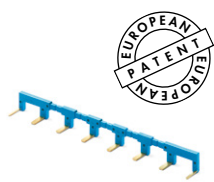
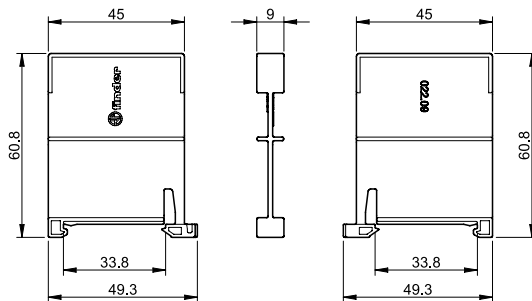

022.18

8-way jumper link for type 22.32, 17.5 mm wide

022.18 (blue)

Rated values

10 A - 250 V

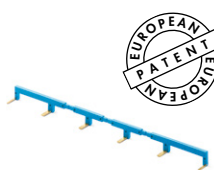
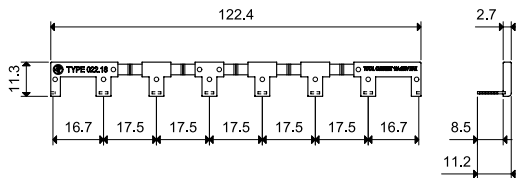

022.26

6-way jumper link for type 22.34, 35 mm wide

022.26 (blue)

Rated values

10 A - 250 V

